



SEKOLAH
.....

PEPERIKSAAN PERCUBAAN TAHUN 2023

KIMIA

Kertas 1

Oktober

1 ¼ jam

Satu jam lima belas minit

JANGAN BUKA KERTAS SOALAN INI SEHINGGA DIBERITAHU

1. Kertas soalan ini adalah dalam dwibahasa.
2. Soalan dalam Bahasa Melayu mendahului soalan yang sepadan dalam Bahasa Inggeris .

Kertas soalan ini mengandungi **29** halaman bercetak

Jawab **semua** soalan
Answer **all** questions

1 Apakah fungsi kebuk wasap?

What is the function of fume cupboard ?

- A** Untuk menyimpan bahan kimia beracun
To store the toxic chemicals
- B** Untuk mencuci dan membersihkan radas
To wash and clean the apparatus
- C** Membekalkan wasap untuk sesetengah eksperimen
Supplied fumes for some experiments
- D** Tempat untuk menjalankana eksperimen yang melibatkan gas bertoksik.
A placed which is conduct an experiments involving toxic gases

2 Bahan yang manakah terdiri daripada ion?

Which substance consists of ions?

- A** Karbon dioksida
Carbon dioxide
- B** Sulfur dioksida
Sulphur dioxide
- C** Kalsium klorida
Calcium chloride
- D** Hidrogen klorida
Hydrogen chloride

- 3 Rajah 1 menunjukkan unsur-unsur dalam kala 3 Jadual Berkala Unsur?

Diagram 1 shows the element in period 3 of the periodic table of elements ?

11	12	13	14	15	16	17	18
Na	Mg	Al	Si	P	S	Cl	Ar
23	24	27	28	31	32	35.5	40

Rajah 1/ *Diagram 1*

Mengapakah saiz atom berkurang daripada natrium kepada argon dalam kala itu?

Why does the size of the atoms decrease from sodium to argon in the periodic?

- A** Bilangan elektron valens bertambah
The number of valance electron increases
- B** Keelektronegatifan unsur bertambah
The electronegativity of elements increases
- C** Tarikan nukleus terhadap elektron valens dalam petala bertambah
The attraction of the nucleus for electrons in the shell increases
- D** Sifat unsur-unsur berubah dari logam kepada bukan logam
The properties of the element changes from metallic to non-metallic
- 4 Antara pasangan sifat fizik berikut, yang manakah benar tentang natrium klorida?
Which of the following pairs of physical properties of sodium chloride is true?
- | | |
|--|---|
| <i>Keterlarutan dalam Air</i> | <i>Kekonduksian elektrik dalam leburan</i> |
| <i>Solubility in water</i> | <i>Electrical conductivity when molten</i> |
| A Larut
<i>Soluble</i> | Mengkonduksi
<i>Conductive</i> |
| B Larut
<i>Soluble</i> | Tidak mengkonduksi
<i>Non-conductive</i> |
| C Tidak larut
<i>Insoluble</i> | Mengkonduksi
<i>Conductive</i> |
| D Tidal larut
<i>Insoluble</i> | Tidak mengkonduksi
<i>Non-Conductive</i> |

5 Antara yang berikut, yang manakah polimer sintetik?

Which of the following is a synthetic polymer?

- I Polietena
Polyethene
- II Selulosa
Cellulose
- III Polystyrene
Polistirena
- IV Protein
Protein
- A I dan II
- B I dan III
- C II dan IV
- D III dan IV

6 Apakah proses yang menukarkan lemak tak tepu kepada lemak tepu?

What is the process that changes unsaturated fats to saturated fats?

- A Penghidrogenan
Hydrogenation
- B Penapaian
Fermentation
- C Pengesteran
Esterification
- D Peneutralan
Neutralisation

7 Antara yang berikut, yang manakah tindak balas perlahan?

Which of the following is a slow reaction?

- A Peneutralan
Neutralisation
- B Pemendakan
Precipitation
- C Pembakaran
Combustion
- D Pengaratan
Rusting

8 1 mol natrium dan 1 mol neon mempunyai

[Jisim atom relatif : Ne = 20 ; Na = 23]

1 mole of sodium and 1 mole of neon have

[Relative atomic mass : Ne = 20 ; Na = 23]

- A Jisim yang sama
The same mass
- B Bilangan atom yang sama
The same number of atoms
- C Bilangan molekul yang sama
The same number of molecule
- D Bilangan elektron yang sama
The same number of electrons

- 9 Tindak balas antara logam besi dengan gas klorin adalah seperti persamaan di bawah.
The following is the reaction between iron metal and chlorine gas.

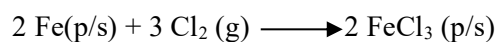

Apakah perubahan nombor pengoksidaan bagi ferum dalam tindak balas ini?

Which of the following shows the changing of oxidation number of iron in this reaction?

- A 0 \longrightarrow +2
B 0 \longrightarrow +3
C +1 \longrightarrow +2
D +1 \longrightarrow +3
- 10 Kehidupan seharian kita dilalui dengan pelbagai tindak balas kimia. Berdasarkan tindak balas di bawah yang manakah tindak balas endotermik?
In our everyday life we come across with variety of chemical reactions. According to the reaction below which reaction is explain about endothermic reaction?
- A Tindak balas peneutralan
Neutralisation reaction
B Pembakaran bahan api
Combustion of fire crackers
C Fotosintesis
Photosynthesis
D Respirasi
Respiration

- 11 Rajah 2 menunjukkan penukaran propena kepada propanol melalui proses X dengan kehadiran mangkin Y.

Diagram 2 shows the conversion of propene into propanol through process X in the presence of catalyst Y.

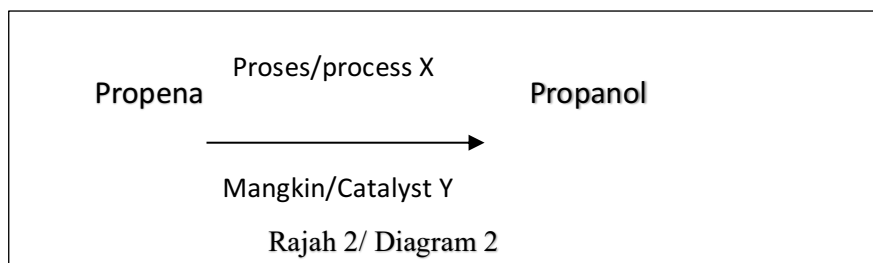

Apakah proses X dan mangkin Y?

What are the process X and catalyst Y?

Proses X	Mangkin Y
<i>Process X</i>	<i>Catalyst Y</i>
A Pengoksidaan <i>oxidation</i>	Vanadium (V) oksida <i>Vanadium (V) oxide</i>
B Pengoksidaan <i>oxidation</i>	Mangan (IV) oksida <i>Manganese (IV) oxide</i>
C Penghidratan <i>Hydration</i>	Asid fosforik pekat <i>Concentrated phosphoric acid</i>
D Penghidratan <i>Hydration</i>	Nikel <i>Nickel</i>

- 12 Aloi X diperbuat dengan mencampurkan besi dengan karbon, kromium dan nikel.

Apakah aloi X?

Alloy X is made by mixing iron with carbon, chromium and nickel.

What is alloy X?

- A Keluli nirkarat
Stainless steel
- B Gangsa
Bronze

- C Keluli
Steel
- D Piuter
Pewter

13 Maklumat di bawah menunjukkan langkah-langkah penyediaan suatu larutan piawai melalui kaedah pencairan.

The information below shows the steps in the preparation of a standard solution through dilution method.

- P - Hitung isi padu larutan yang hendak dicairkan.
Calculate the volume of the solution to be diluted.
- Q - Tambahkan air suling sehingga mencecah tanda senggatan.
Add distilled water until it reaches the calibration mark.
- R - Gunakan pipet untuk mengambil isi padu larutan stok yang diperlukan.
Use a pipette to draw up the needed volume of the stock solution.
- S - Pindahkan larutan ke dalam kelalang volumetrik.
Transfer the solution into a volumetric flask.

Urutan manakah yang menunjukkan langkah-langkah penyediaan larutan piawai yang betul?

Which sequence shows the correct steps in the preparation of a standard solution?

- A Q, P, R, S
- B P, R, Q, S
- C P, R, S, Q
- D R, S, P, Q

- 14 Atom Z mengandungi 13 proton, 14 neutron dan 13 elektron.

Apakah nombor nukleon bagi atom Z?

Atom Z contains 13 protons, 14 neutrons and 13 electrons.

What is the nucleon number of atom Z?

- A 14
B 26
C 27
D 40
- 15 Rajah 3 menunjukkan susunan radas bagi suatu sel elektrolisis.

Diagram 3 shows the apparatus set-up of an electrolytic cell.

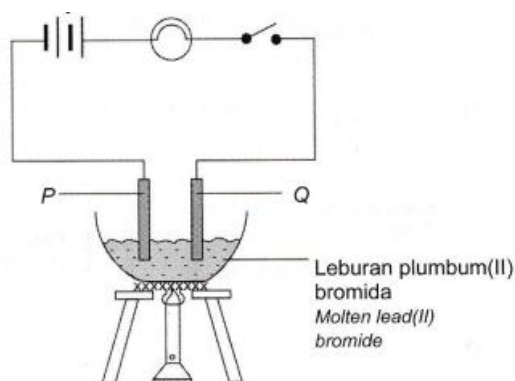

Rajah 3 / Diagram 3

Antara proses dan hasil tindak balas berikut, yang manakah berlaku di elektrod P?

Which of the following process and products occur at electrode P?

	Proses <i>Process</i>	Hasil tindak balas <i>Product</i>
A	Pengoksidaan <i>Oxidation</i>	Bromin <i>Bromine</i>
B	Pengoksidaan <i>Oxidation</i>	Plumbum <i>Lead</i>
C	Penurunan <i>Reduction</i>	Bromin <i>Bromine</i>
D	Penurunan <i>Reduction</i>	Plumbum <i>Lead</i>

16 Berikut ialah pemerhatian apabila garam Y dipanaskan.

The following are the observations when salt Y is heated.

- Gas terbebas mengeruhkan air kapur
Gas released turns lime water chalky
- Baki berwarna hitam
Residue is black in colour

Apakah gas dan baki daripada pemanasan tersebut?

What are the gas and residue from the heating?

	Gas	Baki
	<i>Gas</i>	<i>Residue</i>
A	Karbon dioksida <i>Carbon dioxide</i>	Kuprum (II) oksida <i>Copper (II) oxide</i>
B	Karbon dioksida <i>Carbon dioxide</i>	Kuprum (II) karbonat <i>Copper (II) carbonate</i>
C	Oksigen <i>Oxygen</i>	Plumbum (II) oksida <i>Lead (II) oxide</i>
D	Oksigen <i>Oxygen</i>	Zink oksida <i>Zinc oxide</i>

17 Antara sifat berikut , yang manakah benar bagi kedua - dua kaca dan seramik ?

Which of the following properties are true for both glass and ceramic?

- I Keras tetapi rapuh
Hard but brittle
- II Mengandungi silika
Contain silika
- III Kalis air
waterproof
- IV Penebat elektrik yang baik
Good electrical insulators

19 Jadual 1 di bawah menunjukkan susunan elektron bagi unsur X dan Y.

The table 1 below shows the electron arrangements of element X and Y.

Unsur X <i>Element X</i>	Unsur Y <i>Element Y</i>
2.8.1	2.6

Jadual 1/ *Table 1*

Antara yang berikut yang manakah betul tentang sebatian yang terbentuk daripada tindak balas antara X dengan Y ?

Which of the following is correct about the compound formed from the reaction between X and Y ?

- A Tidak larut dalam air
Insoluble in water
- B Takat lebur dan takat didih yang tinggi
High melting and boiling point
- C Takat lebur dan takat didih yang rendah
Low melting and boiling point
- D Boleh mengkonduksikan arus elektrik dalam semua keadaan
Can conduct electricity in all states

20 Unsur T terletak dalam kala yang sama dengan mangan , Mn dalam Jadual Berkala Unsur.

Antara berikut yang manakah ciri istimewa bagi unsur T ?

Element T is located in the same period as manganese, Mn in the Periodic Table of Elements. Which of the following is the special characteristics of element T ?

- A Takat lebur rendah
Low melting point
- B Membentuk ion berwarna
Form coloured ions
- C Konduktor haba yang lemah
Poor heat conductor
- D Perlu disimpan dalam minyak parafin
Has to be stored in paraffin oil

- 21 Rajah 5 menunjukkan pembentukan satu jenis ikatan di dalam molekul air.

Diagram 5 shows the formation of a type of bond in a water molecule.

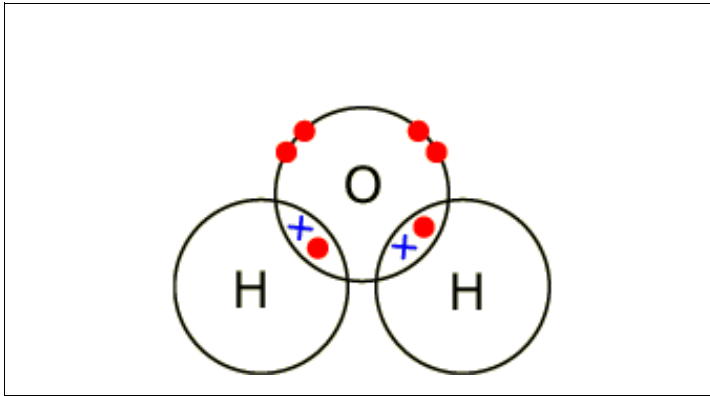

Rajah 5

Diagram 5

Apakah jenis ikatan itu?

What is the type of the bond?

- A Ikatan hidrogen
Hydrogen bond
- B Ikatan logam
Metallic bond
- C Ikatan datif
Dative bond
- D Ikatan kovalen
Covalent bond

- 22 Jadual 2 menunjukkan beberapa jenis ubat dan contohnya.
Table 2 shows a few types of medicines and their example.

Jenis <i>type</i>	Contoh <i>example</i>
Analgesik <i>Analgesics</i>	Q
Antihistamin <i>Antihistamines</i>	P
Ubat psikotik <i>Psychotic drugs</i>	R

Jadual 2
Table 2

Antara berikut, yang manakah mewakili P,Q dan R?
Which of the following represent P,Q and R?

	P	Q	R
A	Antialergi <i>Anti allergies</i>	Parasetamol <i>Paracetamol</i>	Haloperidol <i>Haloperidol</i>
B	Antimikrob <i>Antimicrobials</i>	Aspirin <i>Aspirin</i>	Klozapin <i>Clozapine</i>
C	Kortikosteroid <i>Corticosteroid</i>	Penisilin <i>Penicilin</i>	Kodeina <i>Codeina</i>
D	Antialergi <i>Anti allergies</i>	Haloperidol <i>Haloperidol</i>	Parasetamol <i>Paracetamol</i>

- 23 Antara bahan berikut, yang manakah mengandungi 1.204×10^{24} atom?
Which of the following substances contains 1.204×10^{24} atoms?

- A 1 mol gas nitrogen
1 mol of nitrogen gas
- B 1 mol ammonia
1 mol of ammonia
- C 1 mol air
1 mol of water
- D 1 mol argon
1 mol of argon

- 24 Satu eksperimen dijalankan untuk membandingkan kekerasan dua jenis bongkah, kuprum dan gangsa. Rajah 6 menunjukkan keputusan apabila satu pemberat dijatuhkan ke atas permukaan bongkah gangsa.

An experiment is carried out to compare the hardness of two types of blocks, copper and bronze. Diagram 6 shows the result when a weight is dropped onto the surface of bronze block.

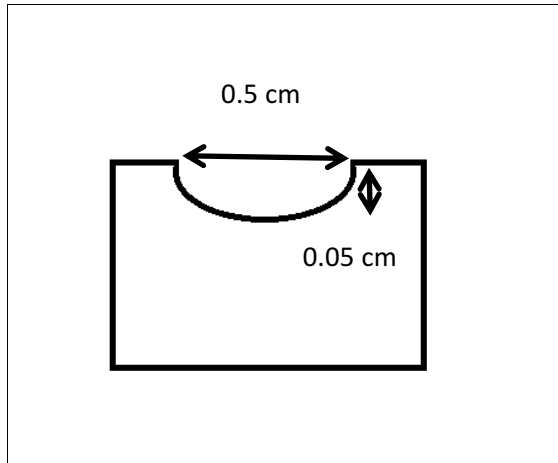

Rajah 6

Diagram 6

Antara yang berikut, yang manakah keputusan apabila pemberat yang sama dijatuhkan ke atas permukaan bongkah kuprum?

Which of the following is the result when the same weight is dropped onto the surface of copper block?

A

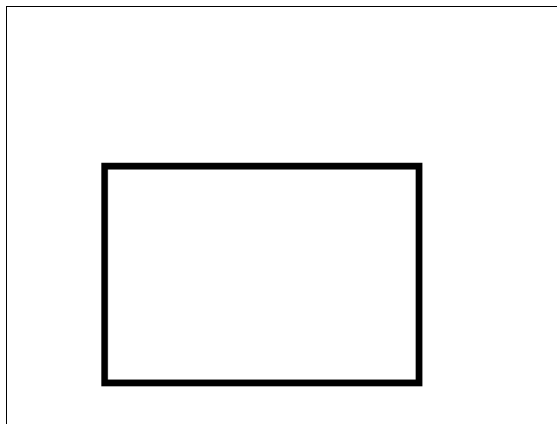

B

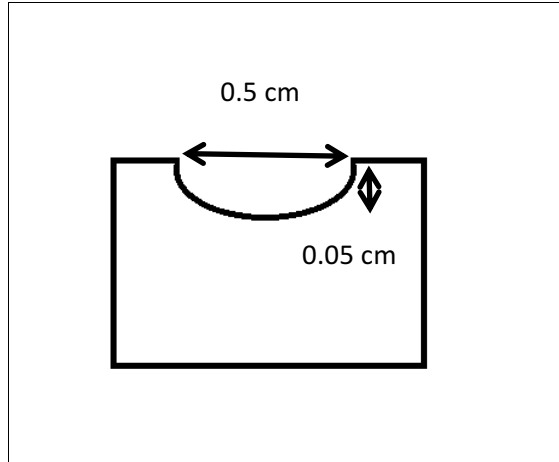

C

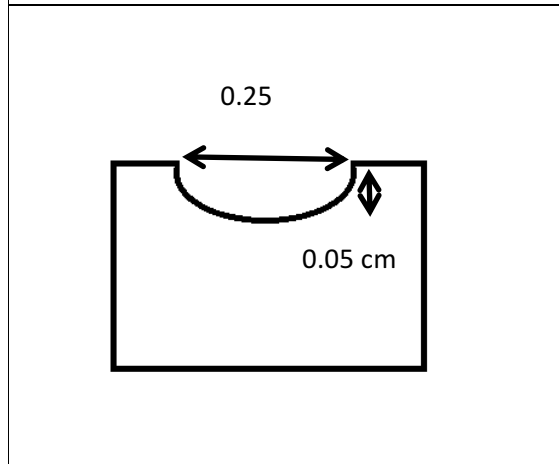

D

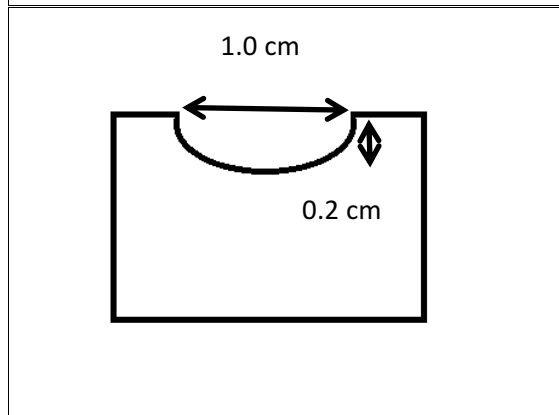

25 Antara bahan berikut, yang manakah sifat elektrolit?

Which of the following is a property of an electrolyte?

- A Elektrolit boleh mengalirkan haba dalam keadaan akueus sahaja.
Electrolyte can conduct heat only in the aqueous state.
- B Elektrolit boleh mengalirkan arus elektrik dalam keadaan leburan dan larutan akueus.
Electrolyte can conduct electricity in the molten state and aqueous solution.
- C Elektrolit boleh mengalirkan haba dalam keadaan leburan sahaja.
Electrolyte can conduct heat only in the molten state
- D Elektrolit boleh mengalirkan arus elektrik dalam keadaan cecair sahaja.
Electrolyte can conduct electricity only in liquid state.

26 Antara berikut, yang manakah menerangkan sifat fizik etanol?

Which of the following describe the physical properties of ethanol?

- I Tidak larut dalam air
Not soluble in water
 - II Mempunyai ketumpatan rendah
Low density
 - III Bukan elektrolit
Not an electrolyte
 - IV Wujud sebagai gas pada suhu bilik
Exist as gas at room temperature
- A II dan IV
II and IV
 - B I dan II
I and II
 - C II dan III
II and III
 - D I, II dan III
I, II and III

27 Ahmad telah menemui sekeping besi tak tulen.

Antara yang berikut, yang manakah betul untuk Ahmad mendapatkan kepingan besi yang tulen melalui proses elektrolisis?

Ahmad found an impure iron strip.

Which of the following is correct in order for Ahmad to obtain a pure iron strip through the electrolysis process?

	Elektrolit / <i>Electrolyte</i>	Anod / <i>Anode</i>	Katod / <i>Cathode</i>
A	Larutan ferum (II) sulfat <i>Iron (II) sulphate solution</i>	Besi tak tulen <i>Impure iron</i>	Besi tulen <i>Pure iron</i>
B	Larutan ferum (II) sulfat <i>Iron (II) sulphate solution</i>	Besi tulen <i>Pure iron</i>	Besi tak tulen <i>Impure iron</i>
C	Ferum (II) hidroksida <i>Iron (II) hydroxide</i>	Besi tak tulen <i>Impure iron</i>	Besi tulen <i>Pure iron</i>
D	Ferum (II) hidroksida <i>Iron (II) hydroxide</i>	Besi tulen <i>Pure iron</i>	Besi tak tulen <i>Impure iron</i>

28 Jadual 3 menunjukkan susunan radas dan pemerhatian untuk mengkaji eksperimen penyesaran logam daripada larutan garamnya.

The table 3 shows the arrangement of the apparatus and observation for studying the metal displacement experiment from its salt solution.

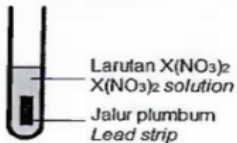
Susunan radas Set-up apparatus	Pemerhatian Observation
	<ul style="list-style-type: none"> • Warna biru larutan $X(NO_3)_2$ menjadi pudar The blue color of solution $X(NO_3)_2$ fades • Kepingan plumbum menjadi nipis The lead strip become thinner • Pepejal perang terendap di dasar tabung uji Brown solids are deposited at the base of the test tube

Jadual 3

Table 3

Antara yang berikut, manakah persamaan bagi tindak balas pengoksidaan dan penurunan yang berlaku dalam tindak balas ini.

Which of the following is the equation for the oxidation and reduction process occur based on this experiment.

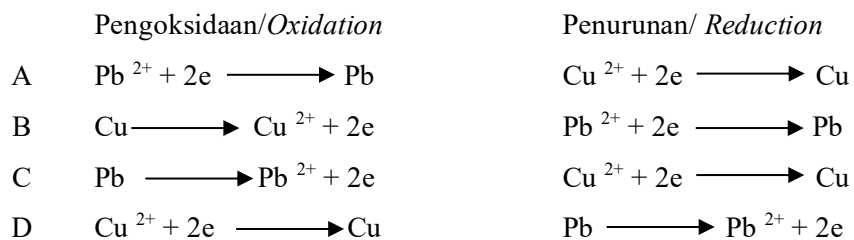

- 29 Rajah 7 menunjukkan sebuah bikar yang mengandungi dua lapisan bahan.
Diagram 7 shows a beaker containing two layers of substance

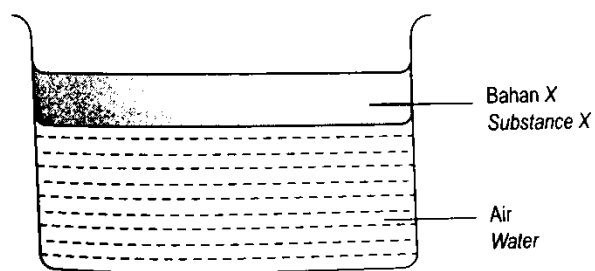

Rajah 7
Diagram 7

Apakah bahan X?
What is substance X?

- A Heksana
Hexane
- B Butanol
Butanol
- C Asid etanoik
Ethanoic acid
- D Asid metanoik
Methanoic acid

30 Antara pernyataan berikut yang manakah benar tentang asid kuat?

Which of the following statement correctly describe a strong acid?

- I Mempunyai nilai pH yang tinggi
Has a high pH value
 - II Mengion sepenuhnya dalam air
Ionise completely in the water
 - III Mempunyai kepekatan ion hidrogen yang tinggi
Has a high concentration of hydrogen ions
 - IV Wujud sebagai molekul dalam air
Exists as molecules in water
- A I dan II
 - B I dan IV
 - C II dan III
 - D III dan IV

31 Paku manakah yang akan berkarat paling cepat?

Which nail will rust the fastest?

A

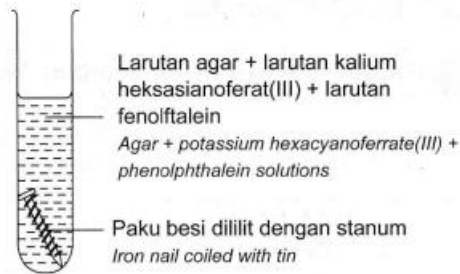

B



C

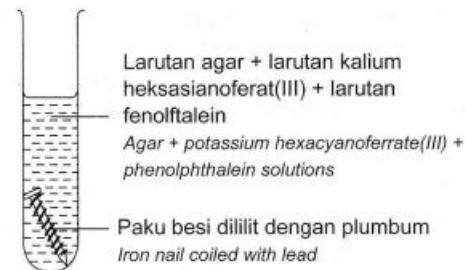

D

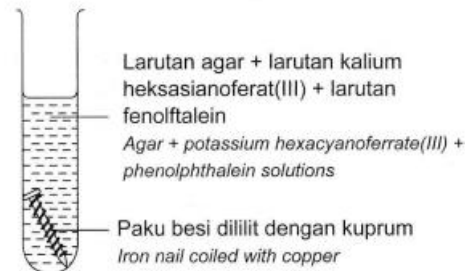

- 32 Dua set eksperimen telah dijalankan untuk mengkaji satu faktor yang mempengaruhi kadar tindak balas. Jadual di bawah menunjukkan bahan tindak balas yang digunakan dalam kedua-dua eksperimen tersebut.

Two sets of experiments were carried out to study a factor affecting the rate of reaction.

Table below shows the reactants used in both experiments.

Set Set	I	II
Bahan tindak balas <i>Reactants</i>	20 cm ³ asid sulfurik 0.5 mol dm ⁻³ + serbuk zink berlebihan <i>20 cm³ of 0.5 mol dm⁻³ sulphuric acid + excess zinc powder</i>	20 cm ³ asid sulfurik 0.5 mol dm ⁻³ + ketulan zink berlebihan <i>20 cm³ of 0.5 mol dm⁻³ sulphuric acid + excess zinc granules</i>

Graf manakah yang menunjukkan lengkung yang betul bagi Set I dan Set II?

Which graph shows the correct curve for Set I and Set II?

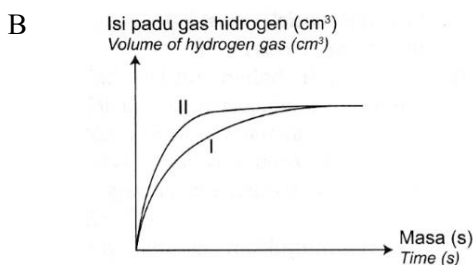
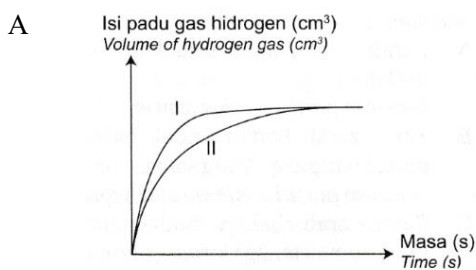

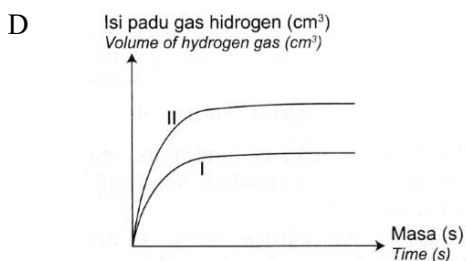
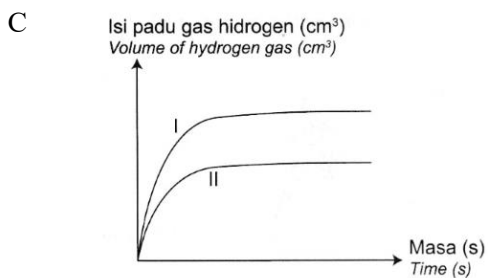

- 33 Persamaan berikut mewakili tindak balas antara magnesium dengan asid hidroklorik.
The following chemical equation represents the reaction between magnesium and hydrochloric acid.

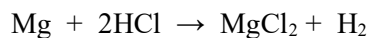

Berapakah isi padu gas hidrogen yang terhasil apabila 5.5 g magnesium bertindak balas dengan asid hidroklorik pada keadaan bilik?

[Jisim atom relatif: Mg = 24, H = 1; Isi padu molar gas = 24 dm³ mol⁻¹ pada keadaan bilik]

What is the volume of hydrogen gas produced when 5.5 g magnesium reacts with hydrochloric acid at room conditions?

[Relative atomic mass: Mg=24, H=1; Molar volume of gas at room conditions = 24 dm³ mol⁻¹]

- A 0.23 dm³
- B 0.46 dm³
- C 5.52 dm³
- D 11.04 dm³

- 34 Sebatian manakah dipadankan dengan betul jenis ikatannya?
Which compound is correctly matched with its type of bonds?

A	Oksigen <i>Oxygen</i>	Ionik <i>Ionic</i>
B	Ammonium <i>Ammonium</i>	Kovalen <i>Covalent</i>
C	Natrium oksida <i>Sodium oxide</i>	Kovalen <i>Covalent</i>
D	Sulfur trioksida <i>Sulphur trioxide</i>	Ionik <i>Ionic</i>

- 35 Rajah 8 menunjukkan sejenis tumbuhan yang boleh ditemui sekitar kawasan perumahan.
Diagram 8 shows a type of plant that can be found around the housing area.



Rajah 8

Diagram 8

Apakah fungsi tumbuhan tersebut sebagai ubat tradisional?

What is the function of the plant as a traditional medicine?

- A Mencerahkan kulit
Brighten the skin
- B Merawat sakit kulit
Treat skin disease

- C Mengeluarkan angin dari dalam badan
Remove wind(gas) from the body
- D Merendahkan tekanan darah dan aras kolestrol
Lower blood pressure and cholesterol level.

36 Rajah 9 menunjukkan suatu eksperimen di dalam bilik gelap untuk membezakan dua jenis hidrokarbon, alkana X dan alkena Y.

Diagram 9 shows an experiment in a dark room to differentiate two type of hydrocarbons, X and Y.

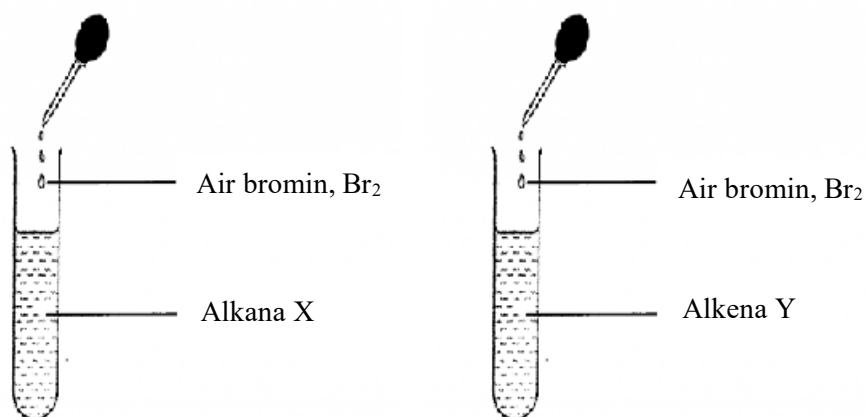

Rajah 9

Diagram 9

Antara yang berikut, yang manakah adalah pemerhatian bagi eksperimen di atas?

Which of the following is the observations for this experiment?

	X	Y
A	Mendakan perang terbentuk di dalam alkana X. <i>Brown precipitate formed in alkane X.</i>	Mendakan perang tidak terbentuk di dalam alkena Y. <i>Brown precipitate did not formed in alkene Y.</i>

B	Alkana X tidak menyahwarnakan warna perang air bromin, Br ₂ . <i>Alkane X does not decolorize the brown color of bromine water, Br₂.</i>	Alkena Y menyahwarnakan warna perang air bromin, Br ₂ . <i>Alkene Y discolorizes the bromine water, Br₂.</i>
C	Alkana X berubah warna dari perang kepada tidak bewarna. <i>Alkane X changes color from brown to colorless.</i>	Alkena Y tidak berubah warna. <i>Alkene Y does not change color.</i>
D	Gelembung gas tidak bewarna terbentuk di dalam sebatian alkana X. <i>Colorless gas bubbles form in the alkane X.</i>	Tiada gelembung gas tidak bewarna terbentuk di dalam sebatian alkana Y. <i>No colorless gas bubbles form in the alkene Y.</i>

- 37 Jadual 4 di bawah menunjukkan pemerhatian bagi tindak balas unsur dalam kumpulan 1 Jadual Berkala Unsur dengan oksigen.

Table 4 shows the observation for the reactivity of group 1 element of periodic table with oxygen.

Unsur <i>Elements</i>	Pemerhatian <i>Observation</i>
X	Terbakar sangat cergas dengan nyalaan ungu <i>Burns vigorously with purple flame</i>
Y	Terbakar perlahan dengan nyalaan merah <i>Burns slowly with red flame</i>
Z	Terbakar dengan cergas dengan nyalaan kuning <i>Burns vigorously with yellow flame</i>

Jadual 4/ Table 4

Antara berikut yang manakah tertib secara menurun yang betul bagi kereaktifan unsur ini dengan oksigen ?

Which of the following is the correct descending order for the reactivity of this elements with oxygen?

- A X,Y,Z
 B X,Z,Y
 C Y,Z,X
 D Z,Y,X

- 38 Rajah 10 menunjukkan susunan radas bagi satu sel kimia.
 Diagram 10 shows the apparatus set up for a voltaic cell.

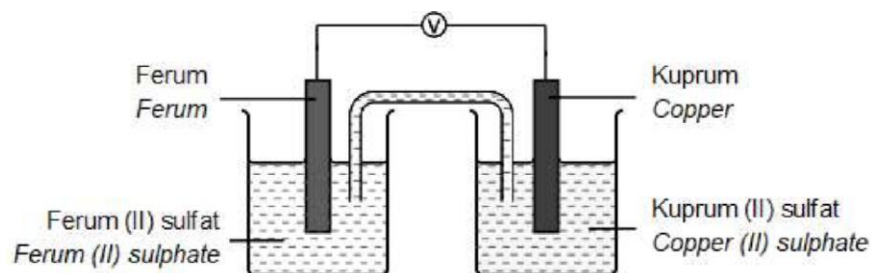

Rajah 10/ Diagram 10

- Hitung nilai E° sel kimia tersebut jika E° sel bagi dua sel setengah adalah seperti berikut:
 Calculate the E° value for this voltaic cell, if E° cell half are:



- A -0.1
 B +0.1
 C -0.78
 D +0.78

- 39 Rajah 11 menunjukkan susunan radas bagi peneutralan antara asid kuat dan alkali kuat
Diagram 11 shows the apparatus set-up for the neutralisation reaction between a strong acid and a strong alkali

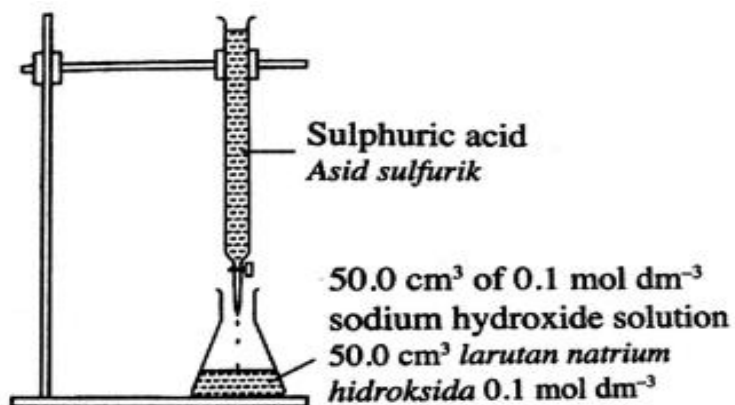

Rajah 11

Diagram 11

25.0 cm³ asid sulfurik meneutralkan 50.0 cm³ larutan natrium hidroksida 0.1 mol dm⁻³.

Apakah kemolaran asid sulfurik?

25.0 cm³ of sulphuric acid neutralises 50.0 cm³ of 0.1 mol dm⁻³ sodium hydroxide solution.

What is the molarity of the sulphuric acid?

- A 0.10 mol dm⁻³
- B 0.15 mol dm⁻³
- C 0.20 mol dm⁻³
- D 0.40 mol dm⁻³

40 Persamaan berikut menunjukkan tindak balas pembakaran metanol.

The following equation shows a combustion reaction of methanol

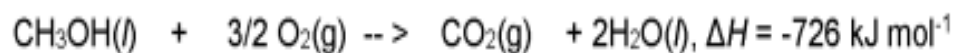

Antara gambar rajah aras tenaga berikut, yang manakah mewakili tindak balas itu?

Which of the energy level diagrams represents the reaction ?

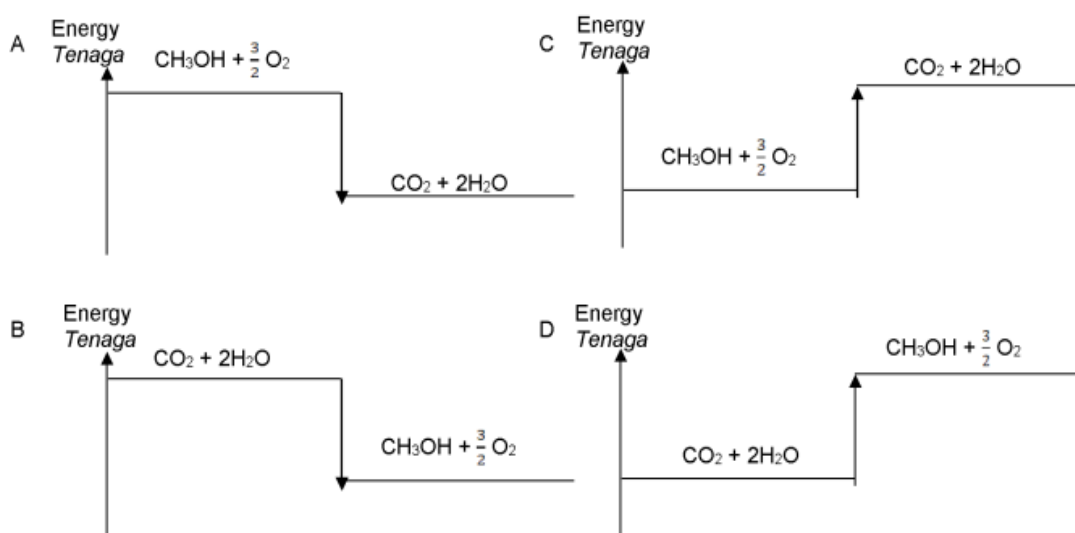

KERTAS SOALAN TAMAT

END OF QUESTIONS PAPER